

Engine	Cummins 6LTAA8.9
Gross Power	221 kW (300 hp) @ 2,000 rpm
Net Power	210 kW (285 hp) @ 2,000 rpm
Operating Weight	23,950 kg
Standard Bucket Size	4.2 m ³
Standard Breakout Force	200 kN
Standard Dump Clearance	3,150 mm

877H WHEEL LOADER



TOUGH WORLD. TOUGH EQUIPMENT.

877H SPECIFICATIONS >>>

ENGINE

Emission Regulation	Tier 2 / Stage II
Make	Cummins
Model	6LTAA8.9
Gross Power	221 kW (300 hp) @ 2,000 rpm
Net Power	210 kW (285 hp) @ 2,000 rpm
Peak Torque	1,487 N · m @ 1,400 rpm
Displacement	8.9 L
Number of Cylinders	6
Aspiration	Turbocharged & Air-to-air intercooled

TRANSMISSION

Transmission Type	Countershaft, power shift
Torque Converter	Single stage, three elements
Maximum Travel Speed, fwd	38.3 km/h
Maximum Travel Speed, rev	26.8 km/h
Number of Speeds, fwd	4
Number of Speeds, rev	3

AXLES

Differential Front Type	Limited slip
Differential Rear Type	Limited slip
Axle Oscillation	±12°

STEERING

Steering Configuration	Articulated
Steering Relief Pressure	20.7 MPa

BRAKES

Service Brake Type	Wet discs brake
Service Brake Actuation	Hydraulic
Parking Brake Type	Flexible shaft control
Parking Brake Actuation	Hydraulic

HYDRAULIC SYSTEM

Main Pump Type	Piston + Gear
Main Relief Pressure	20.7 MPa
Raise	5.7 s
Dump Time	1.3 s
Float Down Time	3.3 s
Fastest Total Cycle Time	10.3 s

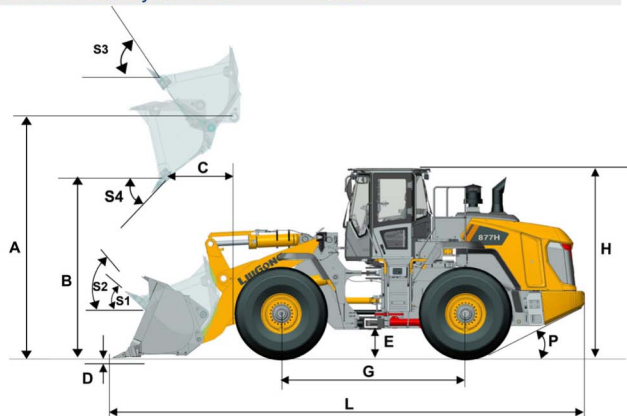

LOADER ARM PERFORMANCE

Tipping Load - Straight	18,806 kg
Tipping Load - Full Turn	16,020 kg
Bucket Breakout Force	200 kN
A Maximum Hinge Pin Height	4,355 mm
B Dump Clearance at Full Height Discharge	3,150 mm
C Dump Reach at Full Height Discharge	1,312 mm
D Maximum Digging Depth, Bucket Level	100 mm
S ₁ Bucket Rollback at Ground Level	45°
S ₂ Bucket Rollback at Carry	49°
S ₃ Bucket Rollback at Maximum Height	60°
S ₄ Maximum Dump Angle at Full Height	45°

BUCKET PERFORMANCE

Reference Bucket	3.5 - 7.0 m ³
------------------	--------------------------

DIMENSIONS

E Ground Clearance	485 mm
G Wheelbase	3,550 mm
H Cab Height	3,580 mm
J Wheel Tread	2,270 mm
K Width Over Tires	2,970 mm
L Length with Bucket Down	9,100 mm
M Turn Angle, Either Side	38°
P Rear Angle of Departure	26°
R ₁ Turning Radius, Bucket Carry	7,470 mm
R ₂ Turning Radius, Outside of Tire	6,625 mm

TIRES

Tire Size	26.5 - 25
-----------	-----------

OPERATING WEIGHTS

Operating Weight	23,950 kg
------------------	-----------

SERVICE CAPACITIES

Fuel Tank	420 L
Engine Oil	30 L
Cooling System	36 L
Hydraulic Reservoir	220 L
Transmission and Torque Converter	50 L
Axles, each	60 L

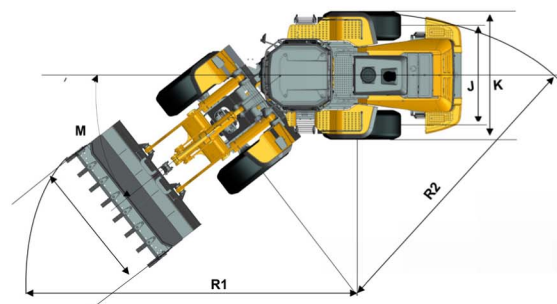

Guangxi Liugong Machinery Co., Ltd.

No. 1 Liutai Road, Liuzhou, Guangxi 545007, PR China
T: +86 772 3886124 E: overseas@liugong.com
www.liugong.com

Specifications and designs are subject to change without notice. Machines shown may include optional equipment.

12/2016 Designed by LiuGong